

Ignites pyrotechnical devices such as airbags or seat belt pretensioners and records ignition current and voltage.

- Support of 4 or 8 times output fire channels (ignition digital switch)
- Individually programmable timers
- Squib- and ignition-line recognition
- Resistance monitoring during recording
- Sync- and status-output for better system integration
- Mechanical and electrical safety interlock
- Automatically activated built-in backup system



TECHNICAL SPECIFICATIONS

Supported channels	4 or 8
Supply voltage	18...22 VDC
Power consumption	Max. 22 W
Trigger	- Trigger-Bus (RS 485), bidirectional, 5V-TTL compatible, 300V insulated (System Connector Socket) - 24V; Trigger-Input, insulated (TRG Socket)
Application	Vehicle crash testing, static deployment (OOP, COP), restraint system development (all-fire-rating), timed switching of actuators
Resolution	16 bit
Sampling Rate	20 kHz, 100 kHz, 400 kHz, 500 kHz, 800 kHz
Max. recording time	262 ksamples per channel 327 ms @ 800 kHz 13 s @ 20 kHz
Ignition current	Adjustable current: 0.1...6 A (0.01 A steps)
Ignition voltage (capacitor charging voltage)	24 V
Current rise time	< 10 μ s
Max. ignition energy	633 mJ
Ignition delay	< 3 μ s to max. 10 s in steps of 0.01 ms @ 800 kHz
Ignition pulse duration	< 0.1 ms to 10 s in steps of 0.01 ms
Communication	IEEE 802.3 i/u Ethernet 10 Mbit/s / 100 Mbit/s
Battery capacity	1,000 mAh, 7.4 VDC (Lithium-Polymer) Yearly maintenance mandatory
Capacitor charging time	~ 5 s
Resistance measurement	Squib (2-wire) / Squib + Ignition line (4-wire)
Squib resistance range	0.5 Ohm – 12 Ohm
Resistance check current	< 10 mA
Resistance measurement range	0.5 Ohm – 12 Ohm
Resistance measurement accuracy	< 0.1 mOhm
Data storage	SRAM 8 MB

Data storage time	2 weeks (battery buffered)
Digital Switch	Solid-state-relay (with same timing capabilities)
Dimensions (L x W x H)	80 mm x 170 mm x 51 mm
Weight	4 channels: 680 g 8 channels: 780 g
Operating temperature	0...50 °C
Shockproof	200 G @ 10 ms
Humidity range	10...70 % RH

Scope of supply

- M=BUS Pro Timer
- Connecting cable for M=BUS Pro Ethernet Gateway (0.35 m, with angular connector)
- Connecting cable for power, network and trigger (0.3 m, with angular connector)
- Network cable, Western/Lemo (3 m)
- Power supply with cable (3 m)
- Safety connector
- Squip simulator

Required for operation

- M=BUS Test Wizard Software

Options

- CrashSoft3 DAS Control Software
- M=BUS Pro Mounting Rail
- M=BUS UPS 5500
- M=BUS Pro Mounting Plate
- Safety interlink cable (0.35 m)
- Sync interlink cable (0.35m)
- Trigger switch

PIN ASSIGNMENT

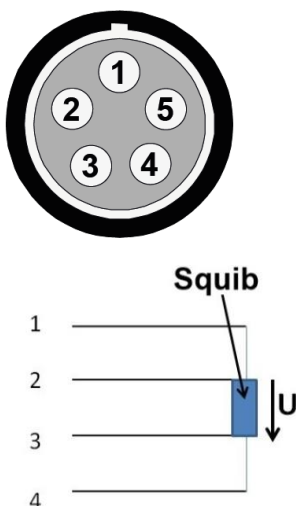

Pin	Description	Pin	Description
1	Out -	4	Sense +: Sense line to the + connection of the ignition tablet (to measure the ignition voltage)
2	Sense -: Sense line to the - connection of the ignition tablet (to measure the ignition voltage)	5	GND
3	Out +: + connection of the ignition tablet		

Figure 1: Pin assignment ignition output (socket view, device)

Use this plug: LEMO FGG.1B.305...

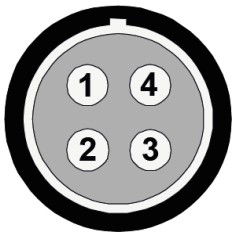

Figure 2: Pin assignment release connector FIRE (socket view, device)

Use this plug: LEMO FGG.0B.304...

Pin	Description	Pin	Description
1	LED +	3	Lock +
2	LED -	4	GND (Lock -)

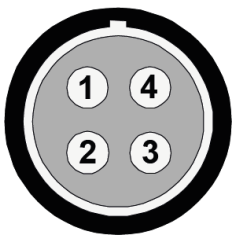

Figure 3: Pin assignment SAFE (socket view, cable)

Use this plug: LEMO FGG.0B.304...

Pin	Description	Pin	Description
1	Status	3	Status interlink
2	Lock +	4	GND

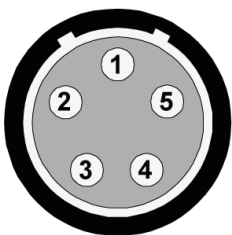

Figure 4: Pin assignment TRG trigger bus (socket view, cable)

Use this plug: LEMO FGB.0B.305...

Pin	Description	Pin	Description
1	24V Trigger input	4	Sync GND
2	Sync +	5	Trigger GND
3	Sync -		

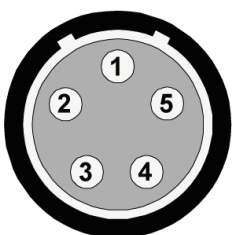
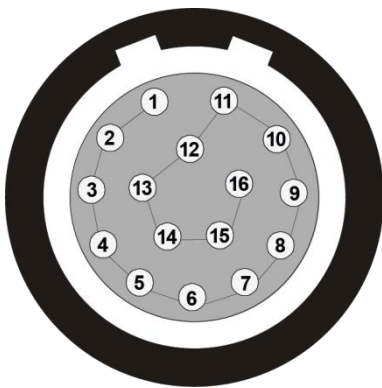

Figure 5: Pin assignment AUX (socket view, cable)

Use this plug: LEMO FGB.0B.305...

Pin	Description	Pin	Description
1	Trigger status collector	4	Sync GND
2	Sync +	5	Trigger status emitter
3	Sync -		



Pin	Description	Pin	Description
1	Network TX +	9	485 A
2	Network TX -	10	485 B
3	Network RX +	11	Supply +22 V
4	Network RX -	12	Supply +22 V
5	Trigger 5 V / 120 mA	13	Supply +22 V
6	Trigger signal B	14	GND
7	Trigger signal A	15	GND
8	Trigger GND,insulated	16	GND

Figure 6: M=BUS system connection (socket view,device)

Use this plug: LEMO FHG.2B.316...

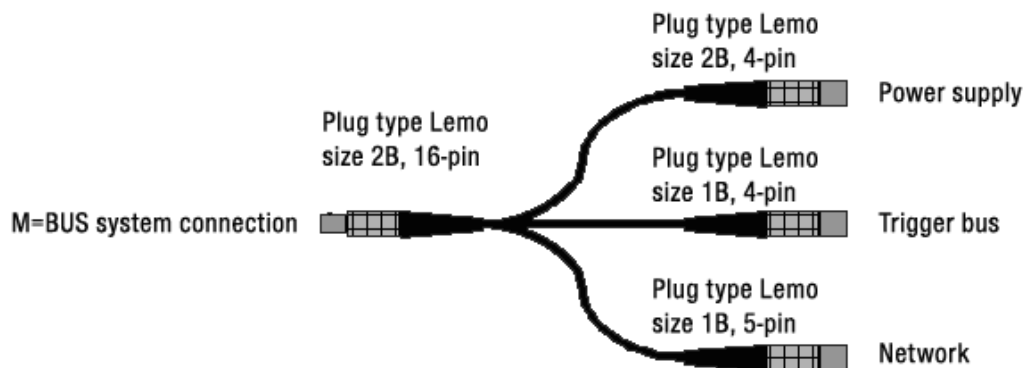

Figure 7: M=BUS Ethernet Gateway adapter cable

TRIGGER BUS

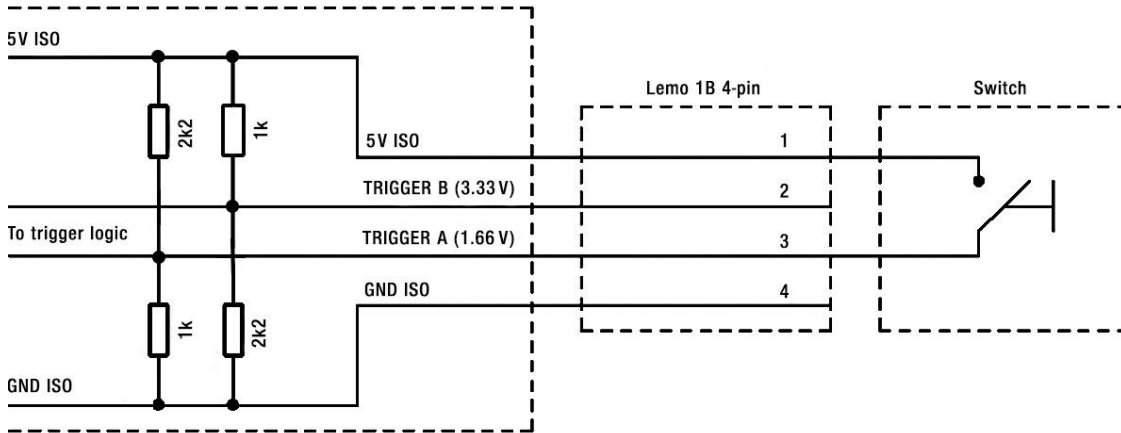

Figure 8: Schematic for trigger switch

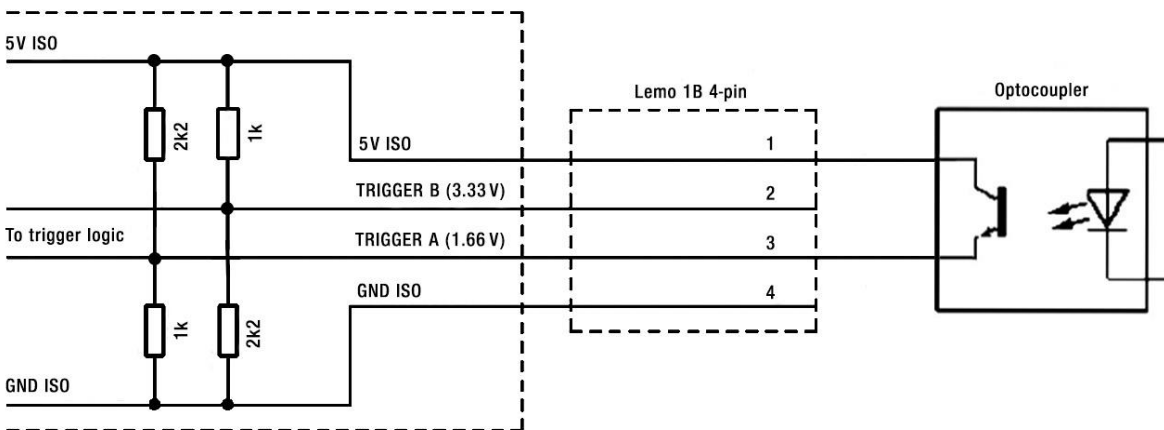

Figure 9: Schematic for optocoupler

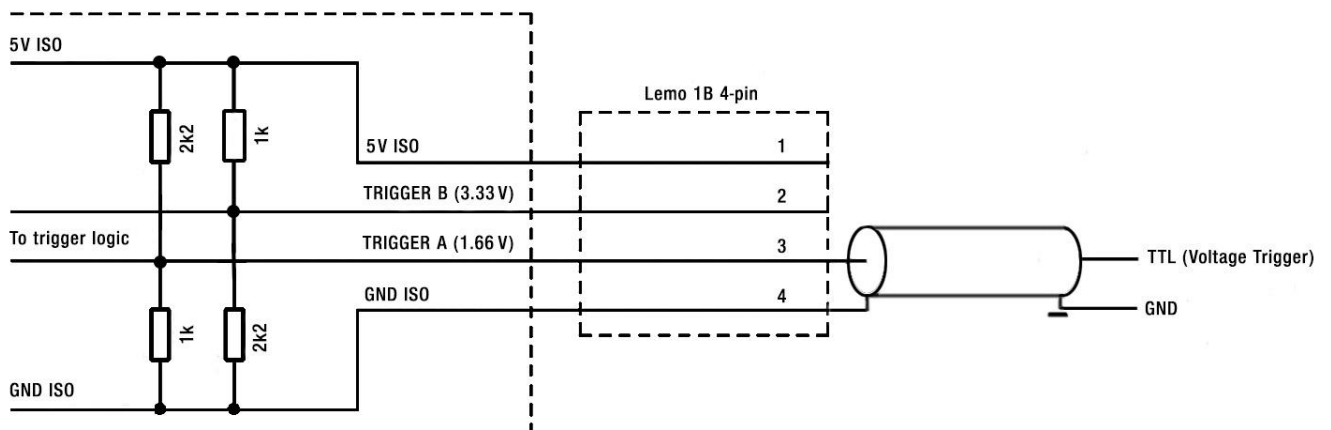

Figure 10: Schematic for TTL