

Stationary interface between M=BUS data loggers and PC with USB 2.0 standard that supplies power, trigger and network signal.

- Support of one bus line
- Plug and Play USB connectivity
- USB full speed
- Integrated terminator



TECHNICAL SPECIFICATIONS

Max. number of M=BUS lines / Max. number of channels	External power: 1 / 48 (M=BUS Lab)
Supply voltage	18...22 VDC
Static power consumption (unloaded)	47 mW
Max. power consumption with full sensor load	22 W
Trigger	Trigger-Bus (RS 485), 5V-TTL compatible, insulated 300 V
Communication	USB 1.1
Dimensions	1 slot
Weight	134 g
Operating temperature	0...50 °C
Humidity range	10...70 % RH

Scope of supply

- M=BUS LAB USB Gateway
- USB Cable for M=BUS USB Gateway
- Trigger switch
- Power supply with cable (3m)
- M=BUS connector set

Required equipment

- M=BUS LAB housing (fronts and screws)
- CrashSoft control software

Options

- M=BUS LAB Analog Logger
- M=BUS LAB Digital Logger

PIN ASSIGNMENT

Pin	Description	Pin	Description
1	USB +5 V	5	Not connected
2	USB Ground	6	Not connected
3	USB Data +	7	Not connected
4	USB Data -		

Figure 1: Pin assignment USB connection (socket view, device)

Use this plug: LEMO FGB.1B.307...

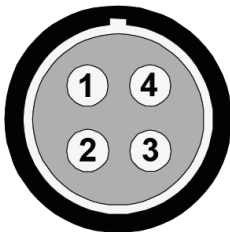

Pin	Description	Pin	Description
1	Trigger 5 V / 120 mA	3	Trigger signal A
2	Trigger signal B	4	Trigger isolated ground

Figure 2: Pin assignment trigger bus (socket view, device)

Use this plug: LEMO FGG.1B.304...

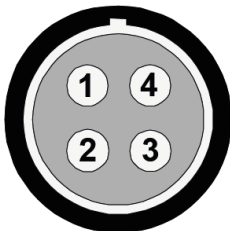

Pin	Description	Pin	Description
1	Supply +22 V	3	Not connected
2	Ground	4	Not connected

Figure 3: Pin assignment power supply (socket view, device)

Use this plug: LEMO FGG.2B.304...

TRIGGER BUS

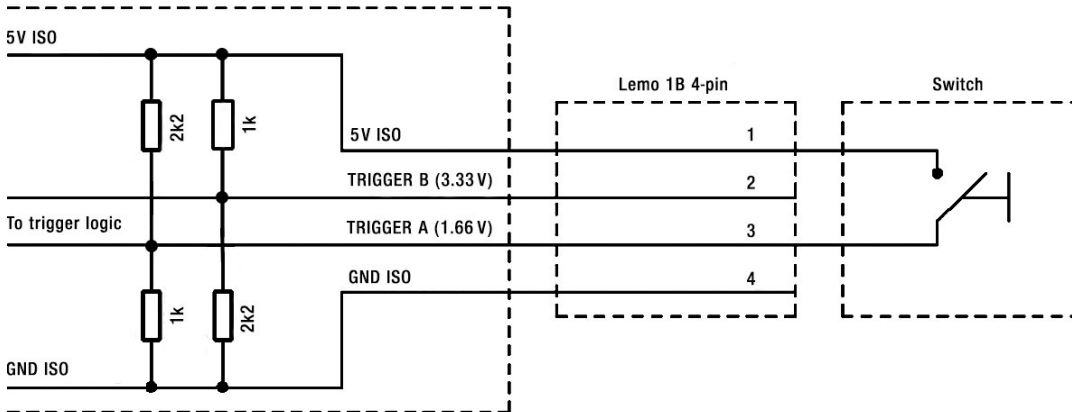

Figure 4: Schematic for trigger switch

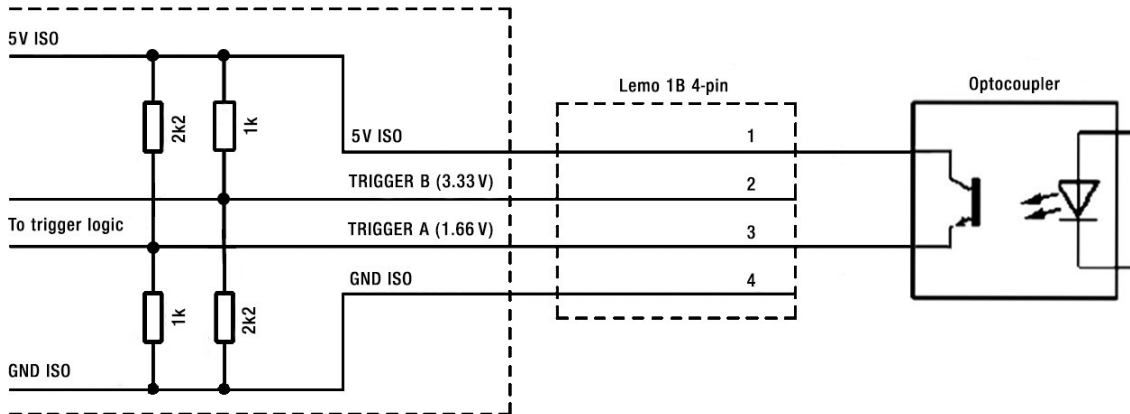

Figure 5: Schematic for optocoupler

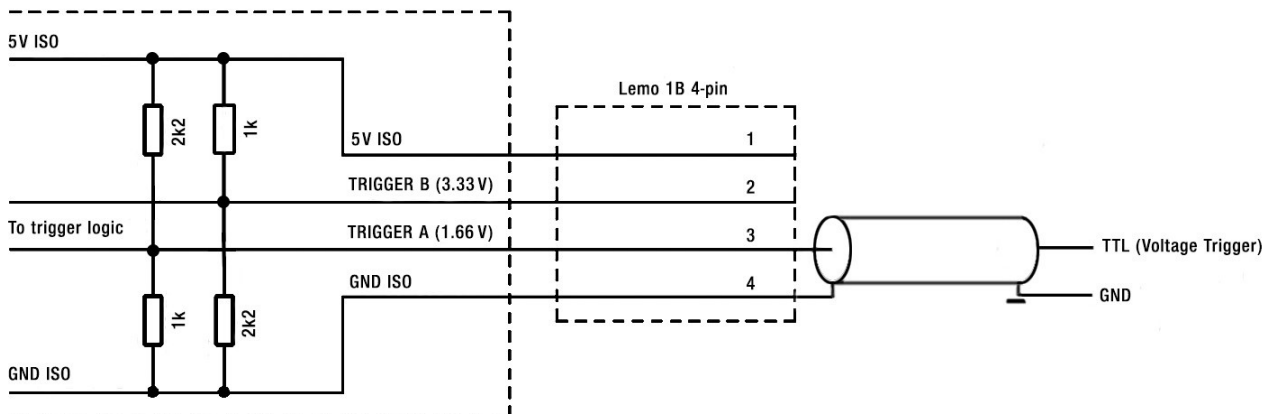

Figure 6: Schematic for TTL