

Seat Belt Load Cell
Capacities up to 16 kN
Code 5BC



Technical Specifications

Principle	strain gauge, full bridge, 350 Ω
Excitation voltage	10 V max.
Capacities, available	6 kN 16 kN Intermediate ranges may be calibrated
Limit load	25% max.
Non-linearity	< 1.0 % F.S.
Temperature range	-10°C to +70 °C
Output	approx. 2 mV/V (see certificate)
Resonance frequency	> 3 kHz
Characteristics	built-in ID-Module with Dallas Chip 6-wire technology built-in shunt linearization circuit

Wiring

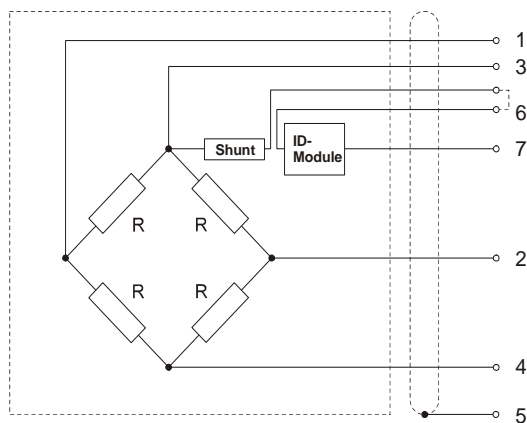

Colors of cable strands and pin assignment (standard):

- 1 = + Excitation = white
- 2 = - Excitation = brown
- 3 = + Signal = green
- 4 = - Signal = yellow
- 5 = Shield = (optional)
- 6 = Shunt = (optional)
- 7 = ID-Module

Type	Cable Connection	Dimensions [mm]				Weight [g] without cable
		D	C	B	A	
6 kN Aluminum	5BC-D15-12 fixed cable	2"	65	35	16,5	57
16 kN Titanium	5BC-D16-22 fixed cable	2"	65	35	16,5	83

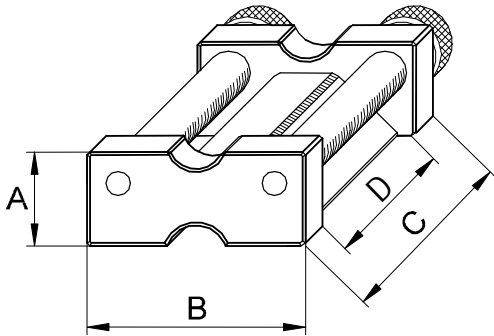

Important notes!

Our seat belt load cells are calibrated using a MESSRING standard belt (extension: 11% – 14%). If the belt force transducer is used with a different belt, deviations in the measurement results might occur. In order to minimize these deviations we recommend to send a sample of the belt you use along with your order. Approximately 10 m of the belt will be needed for adjusting purpose.

The installed linearization circuit board is shock-proof and suitable for up to 10 VDC operation.

Connection Options



fixed cable

Standard:
The cable is glued into the strain relief and soldered on the circuit board inside the sensor.

Option

LEMO connector mounted

With your order please notify the pin configuration required.