

Shockproof External Rechargeable Battery with High Capacity Li-Polymer Technology

Code 4AZ-A2



Figure 1: Shockproof external battery

- **Based on state of the art Li-Polymer technology**
- **Universal external power supply for NA3x and M=Bus**
- **Output 24 VDC, 8 Ah (nominal value, double capacity of 4AZ-A1)**
- **Input 19 to 24 VDC**
- **Compatible to NA33 external battery, type 4AB-F2**
- **Battery pack internally separated from electronics, for easy replacement**
- **Monitoring of voltage, capacitance and temperature, of each cell individually**
- **Monitoring of input and output voltage**
- **Monitoring of load current**
- **Overload and deep discharge protection**
- **RS485 bus interface for communication**

External Rechargeable Battery

The shockproof external rechargeable battery 4AZ-A2 is based on state of the art Li-Polymer technology and is used as an additional power supply for data acquisition systems during crash tests. This battery is designed for all purpose use, especially with NA3x data acquisition systems and M=BUS®.

Technical Data

General

Input voltage	19 to 24 VDC
Input current during charge	3.5 A, typical
	4.0 A, maximum
Output voltage	16.8 to 24 VDC
Output current	0 A, in shut-down state
	0.5 A, minimum load current for battery operation
	10 A, maximum
Charging period	4.0 hours, typical
Capacity	> 7.8 Ah

Dimensions

Width	370 mm
Height	64 mm
Depth	149 mm
Weight	4.9 kg
Mounting hole grid	100 x 350 mm

Block Diagramm

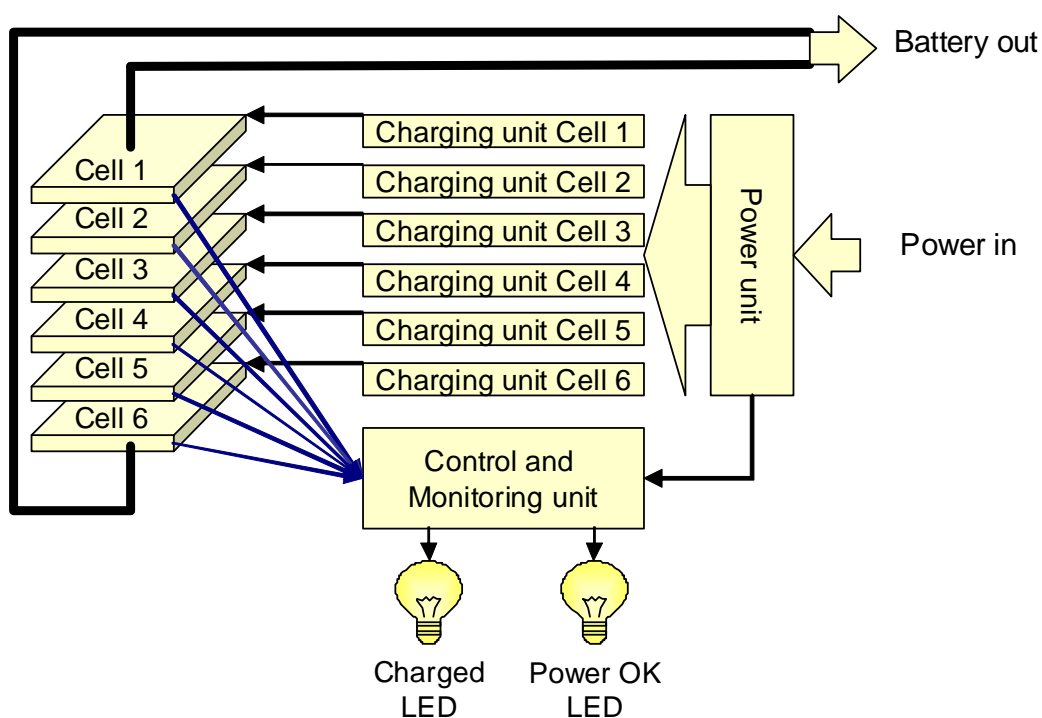

Figure 2: Functional diagram of the battery concept